

HUMA-AIR.COM

Market Leader In Accuracy

Welcome to Huma-Air. We design and manufacture brand- and model specific precision regulators for PCP air rifles.

By using only the highest quality materials such as aircraft grade aluminum, aluminum-bronze, chrome-moly steel and precision belleville springs, our ultra-compact regulators are high performing.

Regulator installation guide GEN3 FX regulator rev: 25-10-22



For adjustment tips, frequently asked questions and a complete list of installation manuals and instructions on how to adjust your Huma-Air regulator

<https://www.huma-air.com/Fitting-instructions>



Or go there directly by scanning the QR code

**Before you start, realize this:**

- Working on a high pressure rifle could potentially be harmful or lethal to you or bystanders if you do not know what you are doing.
- The pictures of the rifle parts in this manual are universal and used as an example to explain the working principle. They might not be equal to the parts in your rifle.
- Do not attempt to install this regulator yourself if you do not have a clear understanding of how these pcp rifles and regulators work.
- Do not attempt to install this regulator if you are not skilled to work on an air rifle; contact your local gunsmith to do the fitting.
- Installation and operation is done completely at your own risk.
- Installing this regulator might void your rifle's factory warranty.
- Your rifle may never be filled higher in pressure as stated in your rifle's manual.
- Do not attempt to fit this regulator in another rifle as mentioned in our order confirmation.
- These regulators are not suitable to use as a CO2 to HPA conversion, this could potentially be harmful or lethal to you or bystanders.
- We cannot be held liable for any accidents in relation to this regulator and its installation.

Before you start, make sure that the rifle is unloaded, remove the magazine and make absolutely sure ALL the air is drained from the pressure tube. If there is a pressure gauge, it will give you just an indication. Dry fire the rifle or follow the manufacturer's instructions and double check to make sure all the air is out of the rifle

If the regulator is fitted and there is no output pressure after filling the pressure tube, something might be wrong causing the airflow to block totally.

Please beware even though there is no output pressure, the pressure tube is fully charged with high pressure air!!

If you are not able to relieve the pressure of the pressure tube according to the manufacturer's instructions or by dry firing the rifle then:

Contact a professional gunsmith to retrieve a solution!

- **DO NOT try to unscrew or to open the pressure tube in any way.**
- **DO NOT try to pierce/drill or to use force to open the pressure tube or unscrew parts in an attempt to relieve the blocked pressure.**
- **These actions can cause serious injury or death to you or bystanders**

FX Impact & FX Crown instruction manual:

Before you open up the packing of your new regulator, read the full manual.

Removal of the factory regulator:

Before you start make sure the rifle is unloaded, and pressure free at **both sides** of the regulator. To remove the factory regulator from the action we would recommend to follow the steps in the video made by Airguns of Arizona.

<https://youtu.be/0OpwyljZlAg>

Huma-Air does use different springs and stacking , we will inform you below.

Please note, never try to remove the piston or setscrew with pliers or anything else that could scratch the surface of the bronze parts. Just one tiny scratch will ruin your regulator and will cause creeping or leaking of the pressure.

Fitting of the new regulator

As the regulator consists of 2 separate parts that will be placed into the action as one. It is not possible to send the regulator fully assembled, when the parts come loose from each other during shipping, the belleville springs would be mixed up. That is why the valve disk and belleville springs need to be placed by yourself following this manual.

After you have removed the factory regulator and you have assembled your new Huma regulator, it will look like this below.

(Note that the spring arrangement pictures can differ between different springstacks.)

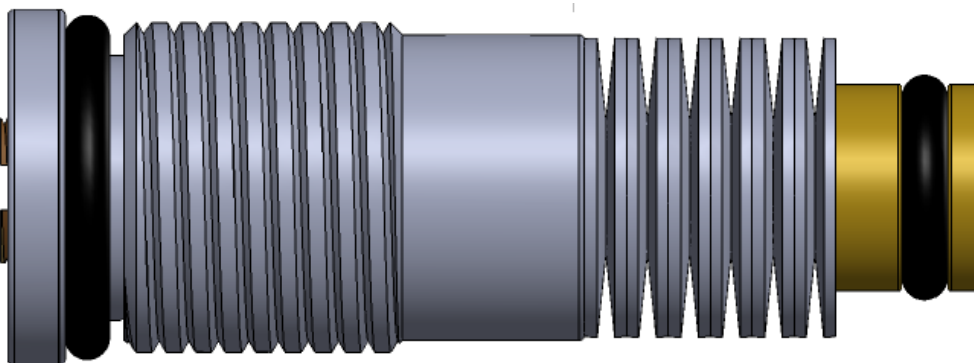

Opening the bag:

When you regulator arrives there will be:

- The regulator body pre-assembled with internal and external o-rings.
- 1 or 2 bags of belleville springs
- 2 valve disks. (They are very tiny so be careful not to lose them)
- Regulator piston with o-ring
- Breech sticker

Assembling the regulator with the correct spring types and stacking:

The latest production of FX airrifles all use the GEN3 regulator that has a 16mm piston and 10mm diameter Belleville springs. These fitting instructions will focus solely on the GEN3 regulator. For instructions on fitting the GEN 1 and 2 regulator we like to point you to the following| :

<http://foto.huma-air.com/foto/Installation%20guide%20FX%20Impact.pdf>

Belleville springs are slightly cone shaped. Look closely so you stack them the correct way.

Huma-Air uses several types and ways of stacking the Belleville springs in our regulators to achieve the best fit for a specific pressure range. Please check the instructions below carefully for the amount of springs you need and in what way they need to be stacked on the piston. Count the springs you need, there can be more in the bag(s) then needed.

Stack the Belleville springs on the regulator piston following the steps below and apply some silicone grease on the springs before stacking them to reduce internal friction.

Figure 1:

Gen 3 regulator, High pressure range, 16 mm long piston, 6 sets of total 12 springs (G3/0.4)

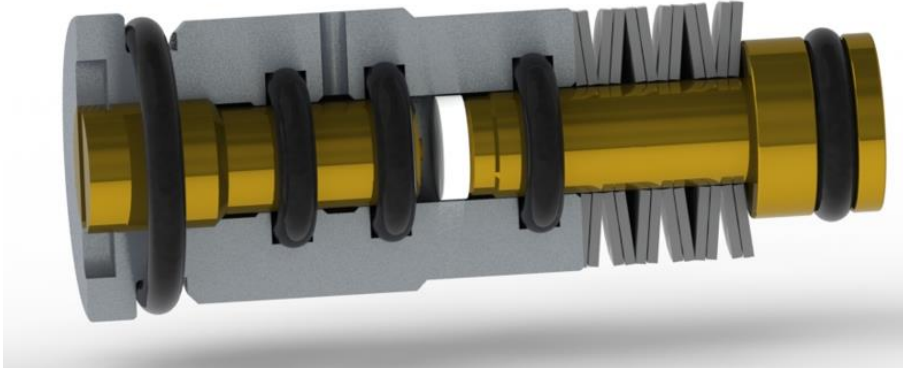

Figure 2:

Closeup of the High pressure range springstack (1311), 16 mm long piston, 6 sets of total 12 springs (G3/0.4)

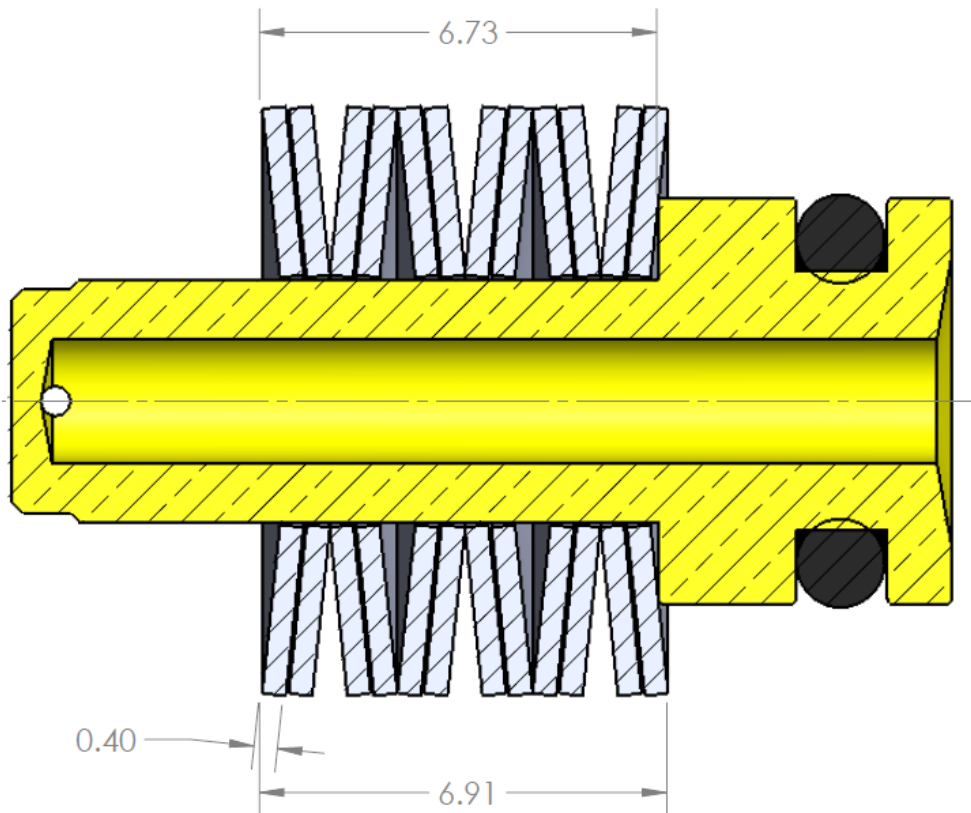

Figure 3:

**Gen 3 regulator, Extra High pressure range, 16 mm long piston, total 8 single stacked springs.
(G3/0,6)**

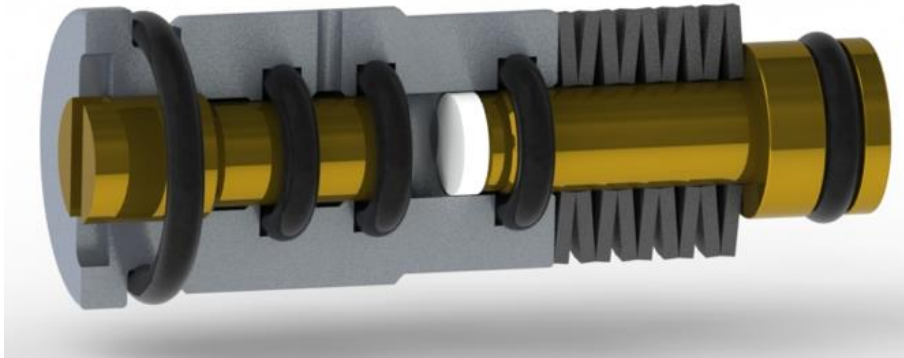

Figure 4:

**Gen 3 regulator, Extra High pressure springstack (1310), 16 mm long piston, total 8 single stacked springs.
(G3/0,6)**

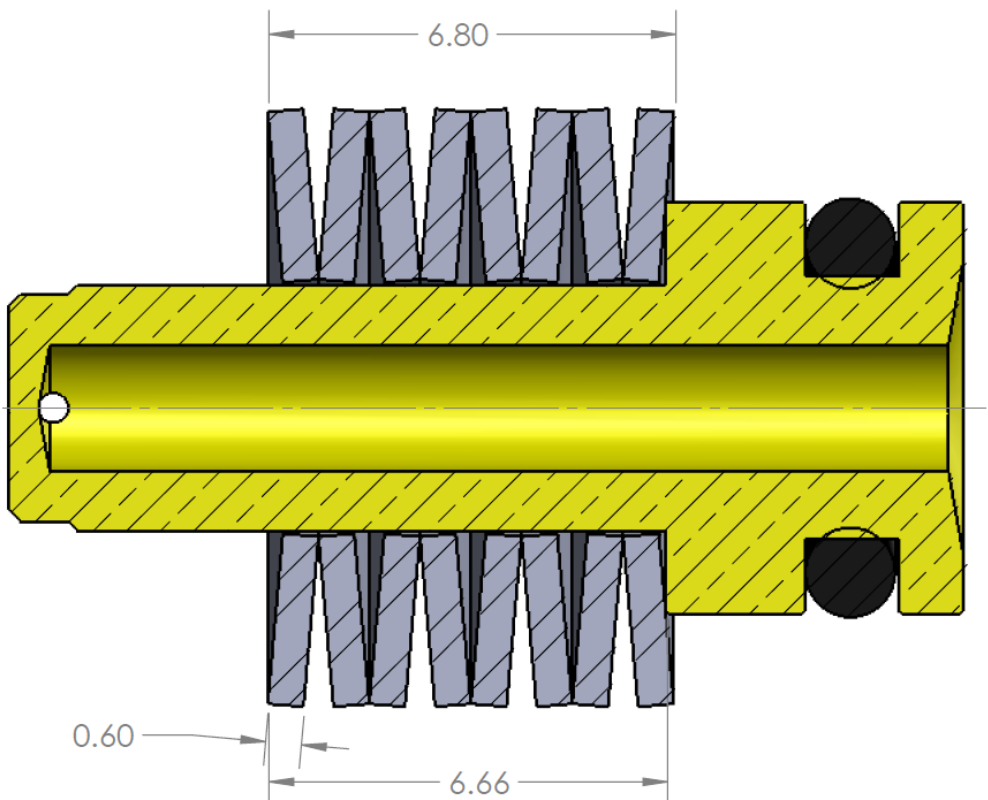

Figure 5:

Gen 3 regulator, Low pressure range, 16 mm long piston, total 10 single stacked springs (G3/0,5)

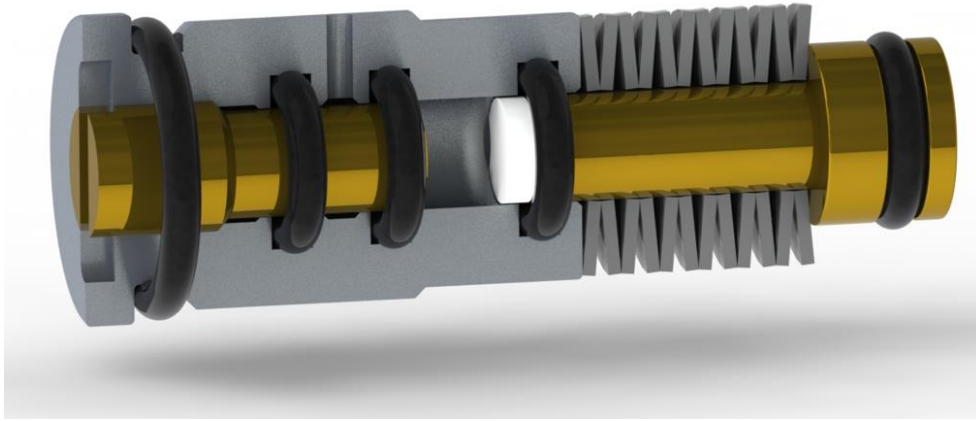
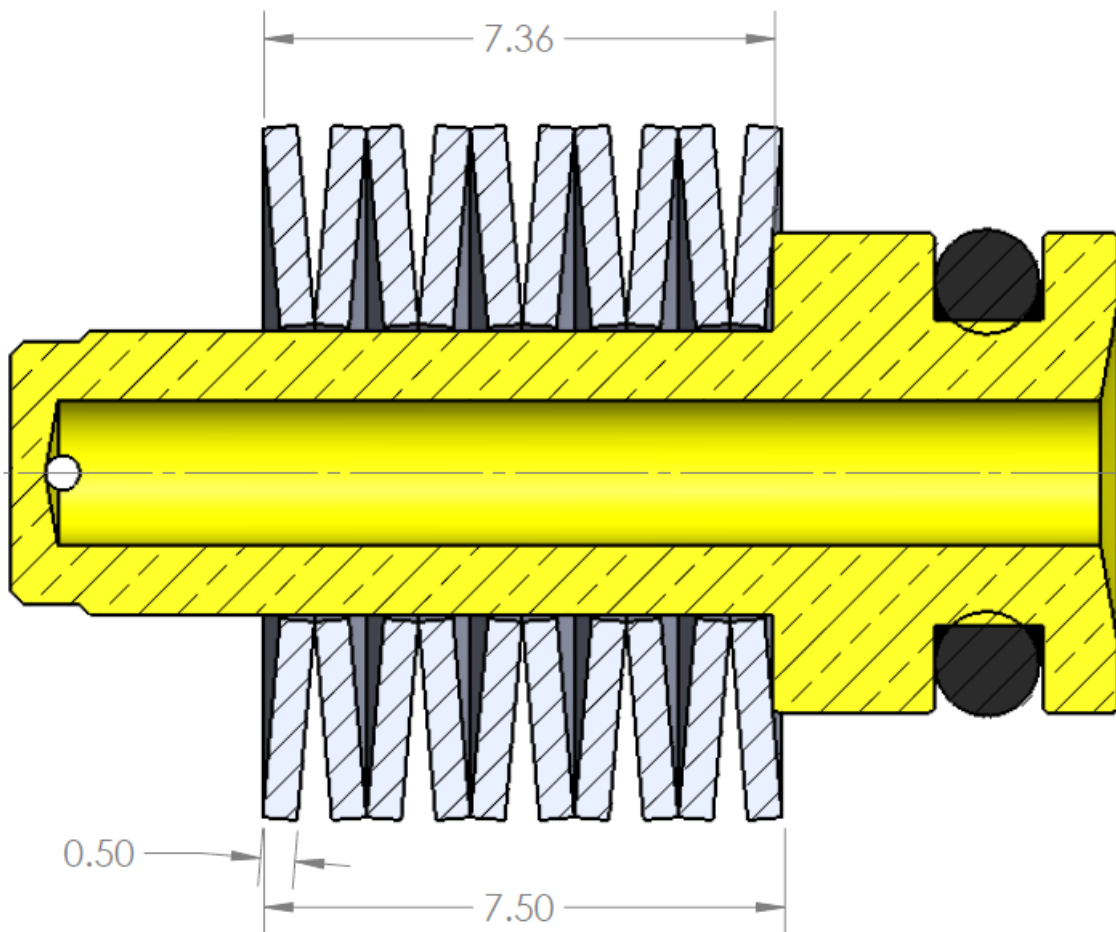

Figure 6:

Gen 3 regulator, Low pressure range (1310), 16 mm long piston, total 10 single stacked springs (G3/0,5)



Very important:

Please apply some silicone grease on the piston o-ring, some on the back side o-ring visible in the regulator house and the cylinder wall inside the action of the rifle where the piston is seated in. The grease will reduce internal friction and take care of smooth movement of the piston.

Applying the valve disk:

In between the piston and the setscrew a very small 4 mm delrin valve disk needs to be placed, see pictures above. Mark one side of the disk with a black marker so you know what side you placed against the setscrew.

You can place the 4 mm valve disk into the regulator body and push it down until it is flat on the tip of the setscrew. Use a blunt tool to push it down so it does not get scratched in any way.



Now you can push the two regulator parts (regulator body and piston) together.

You will feel a bit resistance when it slides into the o-ring and it will be clamped slightly.

As the piston with the belleville washers are just held by a single o-ring. It can easily fall out when you hold the regulator upside down.

Fitting the regulator in the action:

1. Turn the setscrew out until it is flush with the outside of the regulator body as shown below

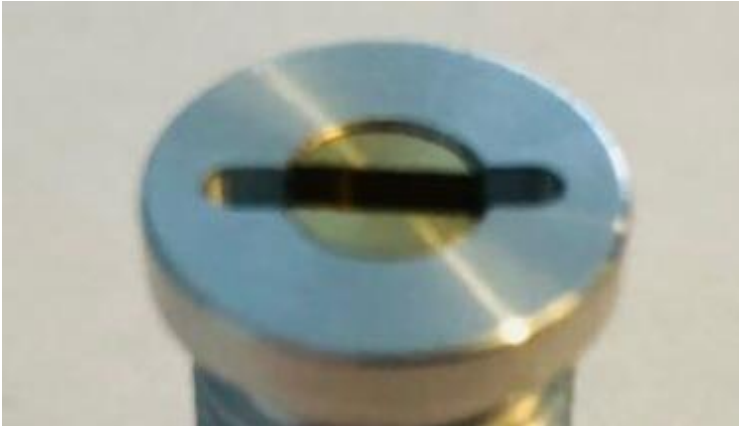

2. Now you can place the regulator in the action in one part and screw it in gently with a 8x1,5 mm screwdriver. Use a matching screwdriver otherwise you will damage the regbody.

TIP: with an Impact, hold the rifle muzzle down so the barrel points to the ground, at an angle, so the regulator piston is on top of the regulator body and cannot fall out of the regulator housing.

You will feel some resistance when the housing is screwed into the o-ring seal that is in the body of the Impact action. When it is in place, do not over tighten it, hand-tight is fine.

3. You can now screw the setscrew in totally, do not use force and stop immediately when you feel any resistance when it touches the valve disk inside.
4. Now with the regulator in place you can cock the rifle, make sure there is no pellet in the magazine or barrel. Cocking the hammer makes sure there is no force on the knock off valve so it closes easy without a lot of pressure.
5. You can screw the bottle on the rifle again so the rifle will pressurized.
It can be possible that some air escapes from the barrel, this is because the reg pressure is too low and needs to be adjusted.
Now take a smaller screwdriver and open up (counter clockwise) the **brass setscrew only** of the regulator and keep an eye on the pressure gauge that indicates the regulated pressure. Please set it careful because it is very sensitive. Do not unscrew the aluminum regbody under pressure!

Never turn the setscrew under pressure beyond the aluminum surface of the regulator housing. The setscrew can be launched and act as a bullet. Always keep the brass setscrew under the surface of the collar of the aluminum regulator house. See below the maximum setting.



Just like the factory regulator the Huma regulator can be turned up in pressure while under pressure. **But you cannot decrease the regulator pressure while the rifle is pressurized. It will ruin your valve disk immediately.**

So if you want a lower pressure, depressurize the rifle first, by unscrewing the pressure bottle and then do some blank shots so there is no pressure in the chamber behind the regulator or unscrew the pressure gauge what shows the regulated pressure for ½ a turn to depressurize the action. Then turn the setscrew in a bit, and pressurize it again so you can turn it up careful to the pressure you want.

Stop turning the setscrew when you are near your preferred output pressure you want and fire some blank shots to set the regulator. After this you can make some fine adjustments.

During the first period of use the regulator need to “bed in” what means the valve disk and tip of the setscrew need to wear into each other.

Maintenance and solving pressure creep:

Inside the regulator there are 3 o-rings. They can be removed by using some dental tools. Reinserting them should be done with a blunt dental tool. We use a small piece of 4 mm plastic rod, 10,5 mm long, to place them. Due to the size of the reg, you would probably need some patience to change them. See the pics above for the positions. The inner part of the housing is not very vulnerable for scratches, but of course be careful and do not use force. Oring grooves should not be scratched!

When a regulator creeps up in pressure, the main issue is probably a damaged valvedisk. Also when you have tried to lower the regulator pressure while under pressure, the disk is probably damaged and needs replacement. A creeping regulator can often be solved by flipping over the disk to the other side or replace it with the extra spare disk what is supplied with the regulator

When setting up the rifle over the chrony, please shoot slowly like you are on the range keeping some time in between shots.

Any comments or tips about this manual are very welcome to make things easier.